

# Kondensator-Schweißstifte ohne Gewinde Typ UT

## Unthreaded CD welding pins, type UT



	Eignung für manuelle und vollautomatische Bolzenzuführung Suitable for manual and fully automatic stud feed	Stahl 4.8 schweißgeeignet (verkupfert)
	Bestellmenge ab 500 Stück Order quantity 500 pcs. minimum	Steel 4.8 suitable for welding (copper-plated)

Preise auf Anfrage   Prices upon request							
Länge Length	Artikel-Nr. Item No.	Artikel-Nr. Item No.	Artikel-Nr. Item No.	Artikel-Nr. Item No.	Artikel-Nr. Item No.	Artikel-Nr. Item No.	Artikel-Nr. Item No.
	Ø3	Ø4	Ø5	Ø6	Ø7,1	Ø8	Ø10,8
6 mm	B06005	--	--	--	--	--	--
8 mm	B06010	B06055	B06205	B06300	--	--	--
10 mm	B06015	B06065	B06215	B06305	B06399	--	--
12 mm	B06020	B06075	B06220	B06310	B06400	B06425	--
15 mm	B06025	B06080	B06225	B06315	B06405	B06430	B06465
16 mm	--	--	--	--	--	B06435	--
20 mm	B06035	B06085	B06240	B06325	B06410	B06440	B06470
25 mm	B06040	B06090	B06245	B06330	B06412	B06445	B06475
30 mm	B06042	B06095	B06250	B06335	B06414	B06450	B06480
35 mm	--	B06100	B06255	B06345	--	B06455	B06485
40 mm	--	--	B06260	B06350	--	B06460	B06490



### Technische Daten | Technical Data

Stift UT  
DIN EN ISO 13918

Pin UT  
DIN EN ISO 13918

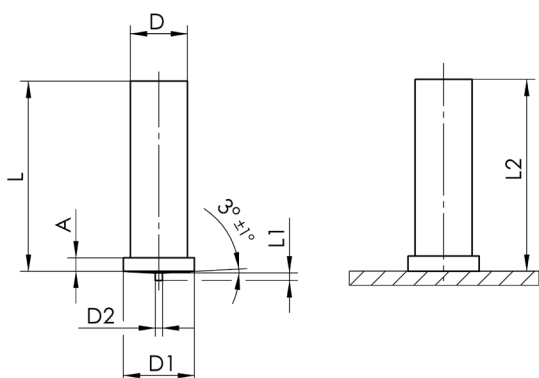

D ± 0,1	L + 0,6	D1 ± 0,2	D2 ± 0,08	L1 ± 0,05	A	L2	$\alpha$ ± 1 °
Ø3	siehe Abmessungen see dimensions	4,5	0,60	0,55	1,4 -0,7	-L -0,3	3 °
Ø4		5,5	0,65				
Ø5		6,5	0,75	0,80			
Ø6		7,5		1,4 -0,6			
Ø7,1		9,0					
Ø8		11,6	0,85	1,8 -0,6	-0,6		
* Ø10,8	± 0,1						

Nicht angegebene Abmessungen auf Anfrage | Other dimensions on request

\* SOYER-Norm | \* SOYER standard  
Alle Maße in mm | All dimensions in mm