

# Kondensator-Schweißstifte ohne Gewinde Typ UT

## Unthreaded CD welding pins, type UT



	Eignung für manuelle und vollautomatische Bolzenzuführung Suitable for manual and fully automatic stud feed	Aluminium EN AW AlMg3
	Bestellmenge ab 500 Stück Order quantity 500 pcs. minimum	Aluminium EN AW AlMg3

Preise auf Anfrage   Prices upon request							
Länge Length	Artikel-Nr. Item No.	Artikel-Nr. Item No.	Artikel-Nr. Item No.	Artikel-Nr. Item No.	Artikel-Nr. Item No.	Artikel-Nr. Item No.	Artikel-Nr. Item No.
	Ø3	Ø4	Ø5	Ø6	Ø7,1	--	--
6 mm	B08000	B08105	--	--	--	--	--
8 mm	B08005	B08115	B08205	--	--	--	--
10 mm	B08010	B08120	B08210	B08305	B08398	--	--
12 mm	B08012	B08125	B08215	B08310	B08399	--	--
15 mm	B08015	B08130	B08220	B08315	B08400	--	--
16 mm	--	--	--	--	--	--	--
20 mm	B08025	B08135	B08225	B08320	B08405	--	--
25 mm	--	B08140	B08230	B08325	B08406	--	--
30 mm	--	--	B08235	B08326	B08407	--	--
35 mm	--	--	--	B08327	--	--	--



### Technische Daten | Technical Data

Stift UT  
DIN EN ISO 13918

Pin UT  
DIN EN ISO 13918

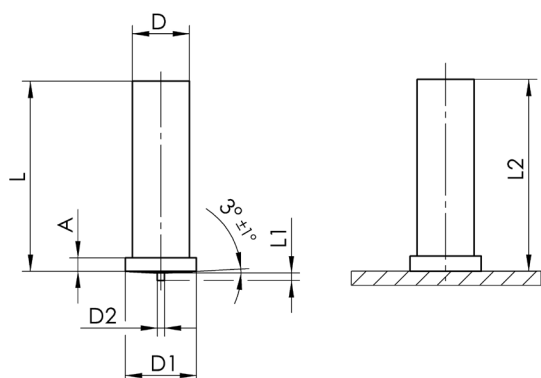

D ± 0,1	L + 0,6	D1 ± 0,2	D2 ± 0,08	L1 ± 0,05	A	L2	$\alpha$ ± 1 °
Ø3	siehe Abmessungen see dimensions	4,5	0,60	0,55	1,4 -0,7	- L - 0,3	3 °
Ø4		5,5	0,65				
Ø5		6,5	0,75	0,80			
Ø6		7,5					
Ø7,1		9,0	0,85	1,4 -0,6			
Ø8		11,6 ± 0,1		1,8 -0,6	-0,6		

Nicht angegebene Abmessungen auf Anfrage | Other dimensions on request

\* SOYER-Norm | \* SOYER standard  
Alle Maße in mm | All dimensions in mm