

Kondensator-Schweißbolzen mit Gewinde, Typ PT

Threaded capacitor discharge welding studs, type PT

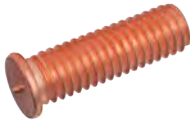

	Eignung für manuelle und vollautomatische Bolzenzuführung Suitable for manual and fully automatic stud feed	Stahl 4.8 schweißgeeignet (verkupfert)
	Bestellmenge ab 500 Stück Order quantity 500 pcs. minimum	Steel 4.8 suitable for welding (copper-plated)

Preise auf Anfrage Prices upon request							
Länge Length	Artikel-Nr. Item No.	Artikel-Nr. Item No.	Artikel-Nr. Item No.	Artikel-Nr. Item No.	Artikel-Nr. Item No.	Artikel-Nr. Item No.	Artikel-Nr. Item No.
	M3	M4	M5	M6	M8	M10	M12
6 mm	B01020	B01095	B01185	--	--	--	--
8 mm	B01030	B01105	B01190	B01265	--	--	--
10 mm	B01035	B01110	B01195	B01270	B01340	--	--
12 mm	B01040	B01120	B01200	B01275	B01345	B01435	--
15 mm	B01045	B01125	B01205	B01280	B01350	B01405	B01450
16 mm	B01050	B01130	B01210	B01285	B01355	--	--
20 mm	B01060	B01140	B01225	B01295	B01360	B01410	B01455
25 mm	B01075	B01145	B01235	B01300	B01365	B01415	B01460
30 mm	B01080	B01150	B01240	B01305	B01370	B01420	B01465
35 mm	--	B01155	B01245	B01310	B01375	B01425	B01470
40 mm	--	B01160	B01250	B01315	B01380	B01440	B01475
45 mm	--	--	B01255	B01320	B01385	--	--
50 mm	--	--	--	B01325	B01390	--	--
55 mm	--	--	--	B01330	B01395	--	--
60 mm	--	--	--	--	B01400	--	--

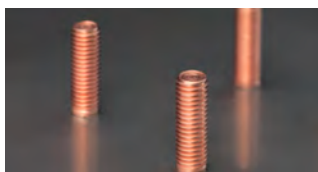
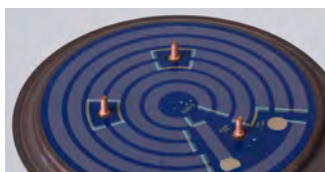

Technische Daten | Technical Data

Gewindebolzen PT
DIN EN ISO 13918

Threaded stud PT
DIN EN ISO 13918

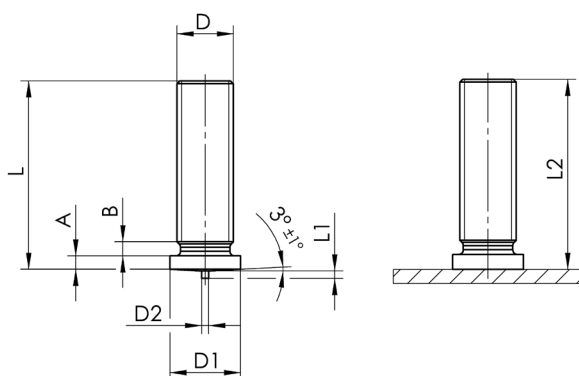

D	L + 0,6	D1 ± 0,2	D2 ± 0,08	L1 ± 0,05	A	B max.	L2	α $\pm 1^\circ$
M3	siehe Abmessungen see dimensions	4,5	0,60	0,55	1,4 -0,7	1,5	~L -0,3	3°
M4		5,5	0,65					
M5		6,5	0,75	0,80	1,4 -0,6			
M6		7,5						
M8		9,0		0,85	1,8 -0,6			
* M10		11,0	3			-0,6		
* M12		12,6 ± 0,1						

Nicht angegebene Abmessungen auf Anfrage | Other dimensions on request

* SOYER-Norm | * SOYER standard
Alle Maße in mm | All dimensions in mm