

Isoliernägel, Typ IN

Insulation nails, type IN



	Manuelle Zuführung oder vollautomatische Zuführung mit Sonder- rüttler Manual feed or fully automatic feed using a special feeder	Stahl 4.8 schweißgeeignet (verkupfert)
	Bestellmenge ab 500 Stück Order quantity 500 pcs. minimum	Steel 4.8 suitable for welding (copper-plated)

Preise auf Anfrage Prices upon request							
Länge Length	Artikel-Nr. Item No.	Artikel-Nr. Item No.	Artikel-Nr. Item No.	Artikel-Nr. Item No.	Artikel-Nr. Item No.	Artikel-Nr. Item No.	Artikel-Nr. Item No.
	Ø2 mm	Ø2,6 mm	Ø3 mm	--	--	--	--
20 mm	B14495	--	B15100	--	--	--	--
25 mm	B14497	--	--	--	--	--	--
30 mm	B14500	B15005	--	--	--	--	--
40 mm	B14505	B15015	B15110	--	--	--	--
50 mm	B14510	B15020	B15120	--	--	--	--
60 mm	B14512	B15025	B15122	--	--	--	--
65 mm	B14515	B15030	B15125	--	--	--	--
70 mm	B14520	--	--	--	--	--	--
85 mm	B14525	B15032	B15130	--	--	--	--
100 mm	B14529	B15035	B15135	--	--	--	--
110 mm	B14530	--	--	--	--	--	--
120 mm	B14535	--	--	--	--	--	--
150 mm	B14550	B15045	B15150	--	--	--	--

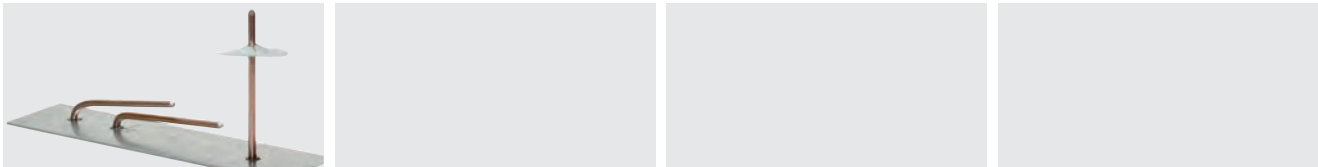

Technische Daten | Technical Data

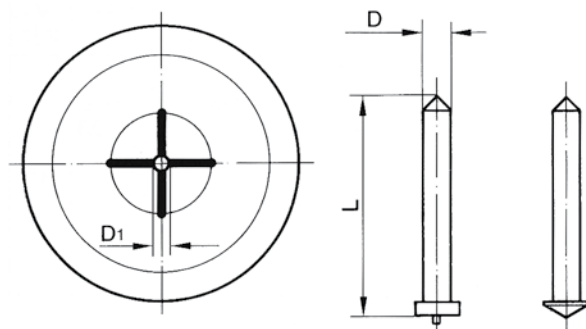

Isoliernägel Typ IN und IN-K mit Clip

Ausführung mit Zündspitze Typ IN oder Kegelspitze Typ IN-K
(Typ IN-K nur für verzinkte Bleche)

Insulation nail type IN and IN-K with clip

Version with ignition tip type IN or conical tip type IN-K
(type IN-K only for galvanized sheet metals)

D	D1	L
ø2	1,8	20 – 150
ø2,6	2,4	30 – 150
ø3	2,8	20 – 150

Toleranzen: D und D₁ ± 0,05 mm | L ± 1 mm

Tolerances: D and D₁ ± 0.05 mm | L ± 1 mm