

Isoliernägel, Typ IN

Insulation nails, type IN



	Manuelle Zuführung oder vollautomatische Zuführung mit Sonder- rüttler Manual feed or fully automatic feed using a special feeder	Rostfreier Stahl A2-50 (schweißgeeignet)
	Bestellmenge ab 500 Stück Order quantity 500 pcs. minimum	Stainless steel A2-50 (suitable for welding)

Preise auf Anfrage Prices upon request							
Länge Length	Artikel-Nr. Item No.	Artikel-Nr. Item No.	Artikel-Nr. Item No.	Artikel-Nr. Item No.	Artikel-Nr. Item No.	Artikel-Nr. Item No.	Artikel-Nr. Item No.
	Ø2 mm	Ø2,6 mm	Ø3 mm	--	--	--	--
20 mm	B15500	--	--	--	--	--	--
25 mm	--	--	--	--	--	--	--
30 mm	B15510	B15698	B16000	--	--	--	--
40 mm	--	--	--	--	--	--	--
50 mm	B15525	B15699	B16005	--	--	--	--
60 mm	--	--	--	--	--	--	--
65 mm	B15535	B15700	B16010	--	--	--	--
70 mm	--	--	--	--	--	--	--
85 mm	B15550	B15705	B16015	--	--	--	--
100 mm	B15555	B15710	B16020	--	--	--	--
110 mm	B15560	--	--	--	--	--	--
120 mm	--	--	--	--	--	--	--
150 mm	B15575	B15715	B16030	--	--	--	--

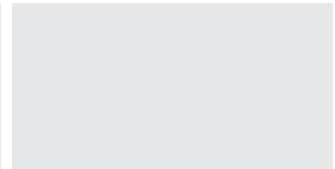
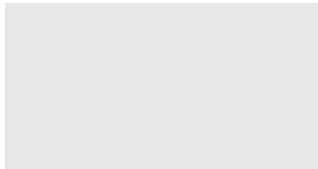

Technische Daten | Technical Data

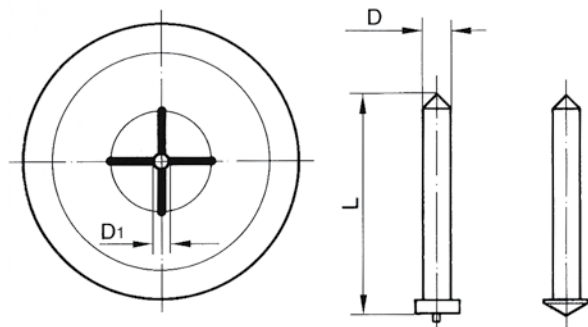

Isoliernägel Typ IN und IN-K mit Clip
Ausführung mit Zündspitze Typ IN oder Kegelspitze Typ IN-K
(Typ IN-K nur für verzinkte Bleche)

Insulation nail type IN and IN-K with clip
Version with ignition tip type IN or conical tip type IN-K
(type IN-K only for galvanized sheet metals)

D	D1	L
ø2	1,8	20 – 150
ø2,6	2,4	30 – 150
ø3	2,8	20 – 150

Toleranzen: D und D₁ ± 0,05 mm | L ± 1 mm

Tolerances: D and D₁ ± 0.05 mm | L ± 1 mm